

DIAMOND[®]

DIAMOND CHAIN COMPANY

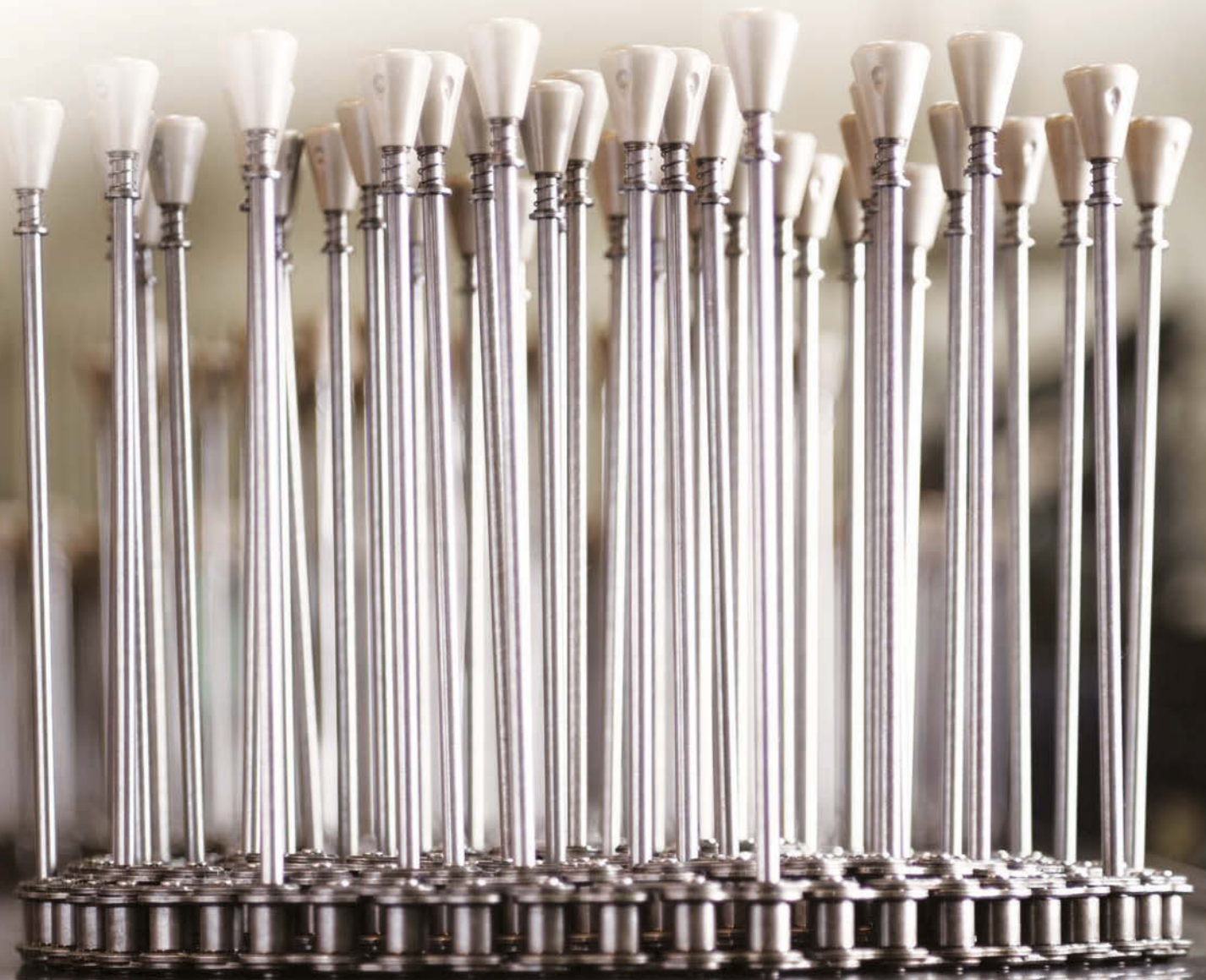

PIN OVEN ROLLER CHAIN

Every Calling is Great, When Greatly Pursued.

OLIVER WENDELL HOLMES

At the Diamond Chain Company, the calling to design and manufacture the world's highest-performing roller chain is greatly pursued every day by teams of passionate technical experts who have made your success their life's work. It's that intensity of focus that some of the world's greatest inventors trusted to provide the drive chains they needed to transform the world. From the Wright Brothers, to Henry Ford, to the global leaders of our time, Diamond® chain is the roller chain most trusted to perform, when performance matters most.

DIAMOND PIN OVEN CHAIN ASME/ANSI 60

Diamond pin oven chains are built with Diamond chain and are available with bendable, breakaway, or stainless steel carrier pins. Diamond pin oven chains are designed with carrier pins that are the actual chain pins, not an attachment, to improve the strength and integrity of the chain, and increase the overall wear span of the chain.

Bendable Pins: Through-hardened medium carbon extended carrier pins are manufactured to produce a tough, ductile pin that is capable of withstanding incidental contact from jams or interference with machine framework. These pins are designed to be easily hand straightened back to their original position.

Breakaway Pins: Case-hardened, low carbon extended carrier pins are manufactured to break off from incidental contact with jammed product, the machine frame, or other obstacles due to misalignment.

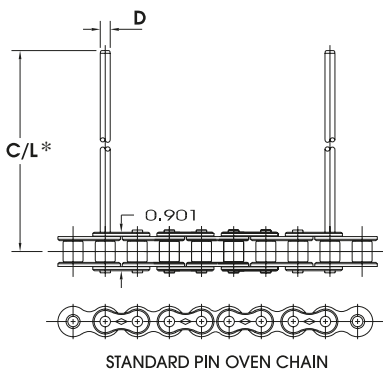

ASME/ANSI Number	Pitch	Roller Width	Roller Diameter	Pin Diameter (D)	Link Plate Thickness	Connecting link pin length	Riveted pin length	Weight lbs/ft kg/m	Average Tensile Strength lbs/N
60	3/4 19.05mm	1/2 12.70mm	.469 11.91mm	.234 6.94mm	.094 29.72mm	1.11 27.69mm	1.04 27.69mm	.990 1.47	8500 lbs. 37810 N

*C/L dimension will depend upon tip and pin extension selected.

DIAMOND RING LEADER® O-RING PIN OVEN CHAIN

Diamond RING LEADER pin oven chains are built with Diamond Chain's O-Ring technology to seal lubricant in and keep contaminants out at operating temperatures up to 450° F /232° C. RING LEADER pin oven chain can be provided with bendable, breakaway, or stainless steel carrier pins.

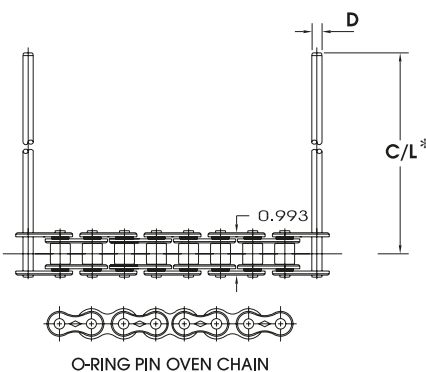
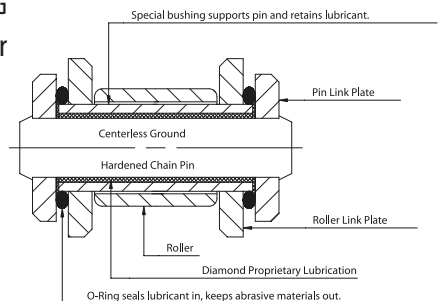

Diamond Number	Pitch	Roller Width	Roller Diameter	Pin Diameter	Link Plate Thickness	Connecting Link Pin Length	Riveted Pin Length	Weight lbs/ft kg/m	Average Tensile Strength lbs/N
50XL0	5/8 19.53mm	3/8 9.53mm	.400 10.16mm	.200 5.08mm	.080 2.032mm	.95 24.13mm	.89 22.61mm	.72 1.07k g/m	6500 28913
60XL03	1/4 19.05mm	1/2 12.70mm	.469 11.91mm	.234 6.94mm	.094 29.72mm	1.17 29.72mm	27.69mm	1.01 1.50k g/m	7700 34251

*C/L dimension will depend upon tip and pin extension selected.

DIAMOND PIN OVEN CHAIN TIP ASSORTMENT

Diamond Chain produces over fifty different tips and pin extensions for use with pin oven chain. These tips are available in a variety of materials including steel, aluminum, heat stabilized nylon, and Diamond Chain's proprietary high temperature PEEK™ which is designed to withstand higher temperatures without drying, cracking, or wearing out. The following are the most common tips, additional tip and pin extension information can be found by contacting the Diamond Chain Company at +44-191-414-8822. 8

	1	2	3	4	5	6	7
D	.234 5.94mm	.247 6.27mm	.215 5.46mm	.468 11.89mm	.575 14.61mm	.352 8.94mm	.875 22.23mm
H	N/A	1.000 25.40mm	.650 16.51mm	.350 8.89mm	.472 11.99mm	.350 8.89mm	1.000 25.40mm
R	.117 2.97mm	N/A	N/A	N/A	.300 7.62mm	N/A	45 deg.

8
.820 (20.83mm)
1.000 (25.40mm)
.125 (3.18mm)

Tips 1-7 are made to order. Tip 8 is in stock.

DIAMOND PIN REPLACEMENT

Diamond pin oven chains are designed without the swaged pin heading so that if a link should need to be repaired, it can be done quickly and easily without grinding pins. Start by removing the air pressure in the tension device and clamp the chain in place. Use a pin extractor to remove the pin link and replace with a repair link. The chain is then ready to resume production.

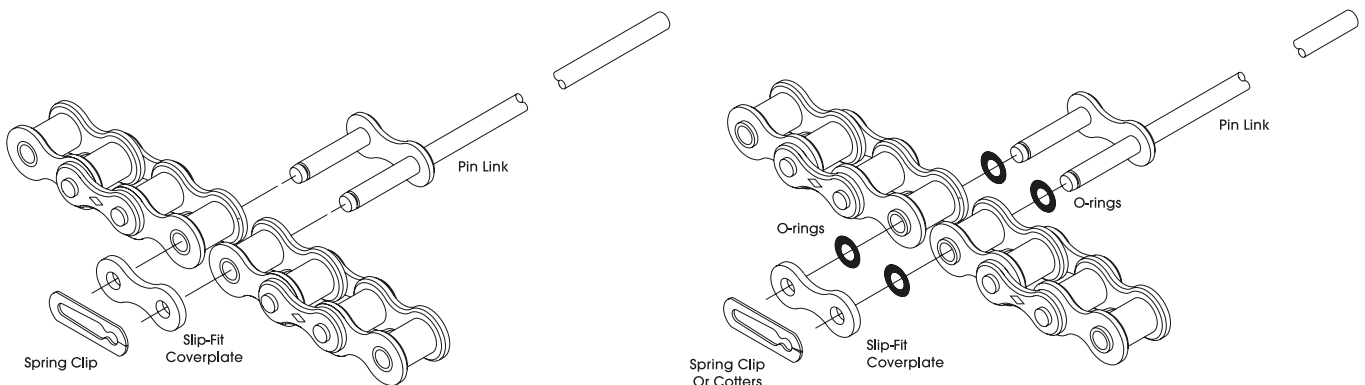

ORDERING INSTRUCTIONS

Ordering Instructions: Use the above drawing showing available tips and specify whether Standard or RING LEADER base chain is desired, the type of pin material (bendable, breakable, or stainless), type of tip configuration, and the extension from the **centerline** of the chain to the end of the pin including the tip.

*PEEK is a trademark of Amoco Performance Products, Inc.

Autorisierter Händler | Distributeur autorisé | Distributore autorizzato | Authorized distributor



H. FRÖHLICH AG | INDUSTRIE TECHNIK

Widenholzstrasse 1
CH-8304 Wallisellen
Tel. +41 44 527 20 00
Fax +41 44 527 20 19
info@hfag.ch | www.hfag.ch

North America

Corporate Headquarters
402 Kentucky Avenue
Indianapolis, Indiana 46225
PH: 1-800 US CHAIN
1-800-872-4246

Dallas Service Center
9120 Premier Row
Dallas, Texas 75356
PH: 1-800-872-4246
Fax: 1-214-631-2374

Sacramento Service Center
1331 Terminal St
West Sacramento, CA 95691
PH: 1-800-872-4246
Fax: 1-916-372-5801
sales@diamondchain.com

Canada/Mexico
PH: 1-317-638-6431

www.diamondchain.com



United Kingdom

Unit 7 – 9
Blaydon Industrial Park
Chainbridge Road
Blaydon on Tyne
NE21 5AB
PH: +44-191-414-8822

sales@diamondchain.co.uk
www.diamondchain.co.uk

Asia

Century Financial Tower, Unit 2005
No. 1 Suhua Road, SIP, Suzhou
Jiangsu Province, China 215021
PH: +86 512-6265-3075

salescn@diamondchain.com

www.diamondchain.com.cn

